



ChargePoint® Networked Charging Stations, by Coulomb Technologies, offer municipalities, corporations, fleets, and utilities, high-reliability, plug-in electric vehicle charging that drivers prefer. The easy-to-use stations provide multiple power options, integrating aesthetics and ergonomics with sturdy construction—ideal for residential, commercial and outdoor public applications.

The CT500 charging station is a 7.2 kW single output station designed for single and multi-family homes, apartments and condominium buildings, light commercial and fleet applications for the North American marketplace. The station delivers Level II (208/240 V @ 30 A) charging and is compatible with plug-in electric vehicles that comply with the SAE J1772™ plug-in electric vehicle charging standard. The station's small size and flexible interfaces for utility Automatic Meter Infrastructure (AMI) make it an ideal solution for homeowners, utilities, fleet managers, and property managers.

To eliminate energy theft and to enhance safety, a card reader option is available for drivers to access and energize the station with a ChargePass™ card. The station's highly visible display guides drivers with instructive messages and can be used to display custom advertisement or greetings for drivers.

ChargePoint Network Enabled

Includes 24/7 driver assistance, station location, station availability, trip mapping, driver billing, and driver notification services. Compatible with remote management, billing, maintenance and other on-demand software applications.

Smart Card Reader Option

Integrated standards-based RFID reader that accepts ChargePass cards. Provides optional driver billing and custom access control, preventing electricity theft and enhancing safety.

Intelligent Power Control

Algorithms ensure power is delivered only when a driver is authorized and the EV connector is properly inserted.

Vacuum Florescent Display with Multiple Language Support

Bright, easy-to-read display used for instructive, advertisement and greeting messages in multiple languages.

Integrated Fault Detection

- Ground Fault Detection: Integrated hardware ground-fault detection circuitry with auto retry and driver notification.
- Over-Current Detection: Disconnects power to prevent nuisance breaker trips at service panel. Auto retry and driver notification.
- Plug-Out Detection: Algorithm disengages power and notifies the driver when a plug is removed.
- Charging Complete Detection: Algorithm detects completion of EV charge and notifies the driver.

Over-the-Air Station Upgrade

Upgrade station firmware remotely over-the-air to keep charging station current with future and evolving EV charging needs.

Utility Grade Energy Meter

Integrated power metering circuitry provides accurate bi-directional energy measurement.

Remote Diagnostics and Control

Real-time remote alarm monitoring and control minimizes the need for on-site maintenance.

Network Interface

Wireless mesh and cellular network interface allows seamless integration with back office business systems, utility Automatic Metering Infrastructures (AMIs), or home area networks.

Smart Grid Compatible

Utility grade meter and smart-grid interfaces enable demand response and Time-Of-Use (TOU) pricing.



Coulomb Technologies, Inc.
1692 Dell Ave.
Campbell, CA 95008-6901 USA
US toll free: +1-877-370-3802
www.coulombtech.com
www.mychargepoint.net

WALL MOUNT (CT503) DIMENSIONS

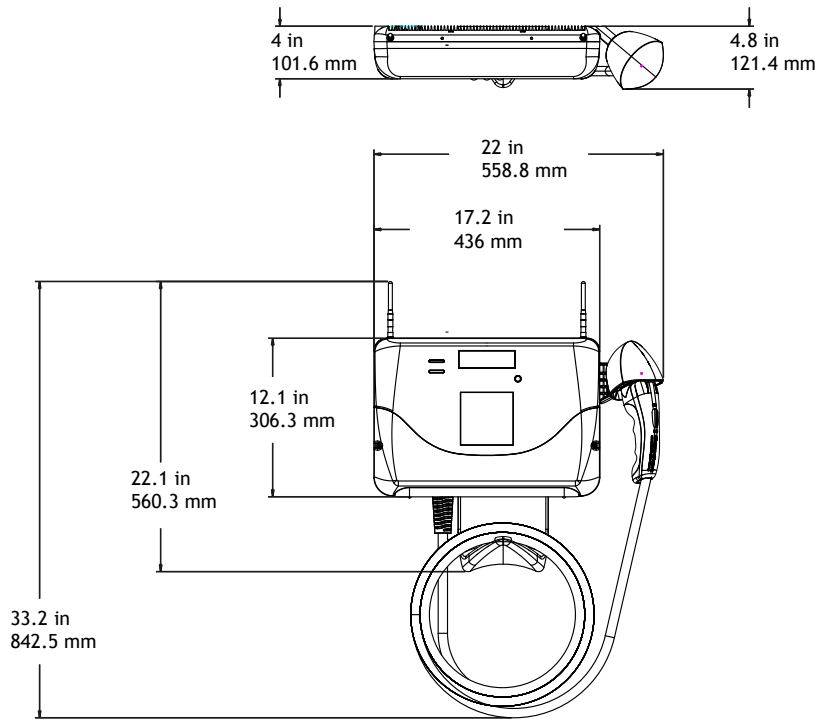

WALL MOUNT (CT503) MOUNTING DIMENSIONS

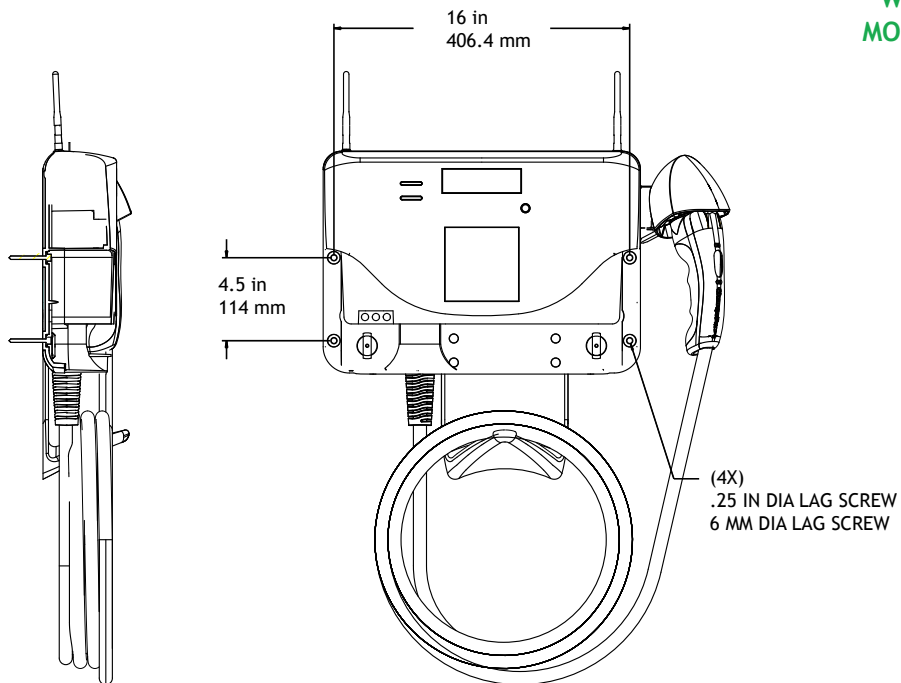

Electrical Input

Input Power	7.2 kW
Input Voltage	208/240 VAC
Input Current	30 A
Input Power Connections	Line 1, Line 2, Earth
Required Service Panel Breaker	40 A double pole breaker (non-GFCI type) on dedicated circuit
Standby Power	5 W typical

Electrical Output

Output Charging Power	7.2 kW
Output Voltage	208/240 VAC
Output Current	30 A
Output Charging Connector	SAE J1772™ EV connector on 18' (5.48 m) cable

Functional Interfaces

Card Reader	ISO 15693, 14443
Ground Fault Detection	20 mA CCID with auto retry (15 minute delay, 3 tries)
Plug-Out Detection	Power terminated per SAE J1772™ specification
Power Measurement	2% @ 15 minute intervals
Local Area Network	2.4 GHz 802.15.4 dynamic mesh network
Wide Area Network	Commercial CDMA or GPRS cellular data network

Safety and Operational Ratings

Safety Compliance	UL Listed for USA and cUL certified for Canada; Complies with UL 2594, UL 2231-1, UL 2231-2, UL 1998, UL 991, NEC Article 625
Surge Protection	6 kV @ 3,000 A. In geographic areas subject to frequent thunderstorms, supplemental surge protection is recommended.
EMC	FCC Part 15 Class B
Operating Temperature	-22° F to 122° F (-30° C to +50° C)
Operating Humidity	95% non-condensing
Enclosure	NEMA 3R
Terminal Block Temperature Rating	212° F (100° C)
Maximum Charging Stations per 802.15.4 Radio Group	100. Each station must be within 150 feet "line of sight" of at least one other station.
Approximate Shipping Weights	26 lbs (12 kg)

Coulomb Technologies, Inc. reserves the right to alter product offerings and specifications at any time without notice, and is not responsible for typographical or graphical errors that may appear in this document.

WALL MOUNT (CT503)



Ordering Information

Specify model number followed by the applicable code(s). The order code sequence is:

Model-Modem-SIM-Local Area Network-Warranty

Option	Order Code
Model	
Wall Mount	CT503
Modem*	
Integral CDMA ChargePoint Gateway Modem	-CDMA
Integral GPRS ChargePoint Gateway Modem	-GPRS
SIM	
USA GPRS SIM	-SIM1
Canada GPRS SIM	-SIM2
Card Reader	
RFID Card Reader	-RFID
Local Area Network (LAN)*	
802.15.4 wireless mesh interface	-ZIG
Warranty	
5 Year Parts Only Extended Warranty: Gateway	-EW5GW
5 Year Parts Only Extended Warranty: Gateway, LAN, and Card Reader	-EW5GWRFDZIG
5 Year Parts Only Extended Warranty: Card Reader and LAN	-EW5RFIDZIG

*Specify at least one modem or LAN option (or both)

Order Code Examples

If ordering this	The order code would be
Wall Mount with CDMA Gateway Modem, RFID Card Reader, and LAN	CT503-CDMA-RFID-ZIG
Wall Mount with GPRS Gateway Modem, and USA GPRS SIM	CT503-GPRS-SIM1
Wall Mount with Card Reader, LAN, and 5 year extended parts warranty	CT503-RFID-ZIG-EW5RFIDZIG

For pricing and additional product information, contact the distributor in your area. For a complete list of distributors, go to www.coulombtech.com and click Purchase.

Coulomb Technologies, Inc. - 1692 Dell Ave. - Campbell, CA 95008-6901 USA
 408.841.4500 - 877.370.3802 - info@coulombtech.com
www.coulombtech.com - www.mychargepoint.net

Listed by Underwriters Laboratories Inc. 